

Belt Drive Flange Facers

These solid ring steel Belt Drive Flange Facing machines are designed to cover a wide range of applications, with operator efficiency built into the overall design, rigging and packaging of each unit. These machines feature belt drive with adjustable cam bearings, driven with a pneumatic motor allowing them to be used in more precise applications. The slide and compound are a precision ball rail design which produces a very smooth and precise travel. The compound can swivel to any angle off vertical, which allows these flange facers to machine all types of gasket surfaces.

Every machine has a cover that encapsulates the belts, pulleys, and moving parts. to safely eliminate pinch points. Each machine is supplied with swivel lifting eyes, and lifting cables that assist in easy mounting and set up. Alignment of the machine to the gasket surface is quick and easy using the adjustable jaws supplied with each machine.

The automatic trip feed and gears can be used for hands-free machining of various RMS finishes on gasket surfaces. This allows full user control, while safely eliminating contact with rotating parts and pinch points. Machines are packaged with a 1/2 inch tool holder, air motor, oiler, air hose with control valve, and lifting cables.

Back facing attachments can be supplied for each size. Belt Drive Flange Facer sizes include 21in (533mm), 30in (762mm), 32in (813mm), 40in, 42 inch, 52 inch, 62 inch, 72 inch and 82 inch.

Tool Advantages

- Belt Driven
- Both Radial and Axial feeds
- Manual and Automatic feeds
- All types of RMS Finishes
- Tool holder for 1/2 inch tool bits
- Compound swivels to machine all angles, from 0 to 90 degrees
- Rigid Construction to maximize performance
- Adjustable jaws for fast 4 jaw set up
- Back Facing Attachments available
- All rotating parts concealed behind solid cover
- Pneumatic and hydraulic motors
- Lifting cables and swivel eyes provided

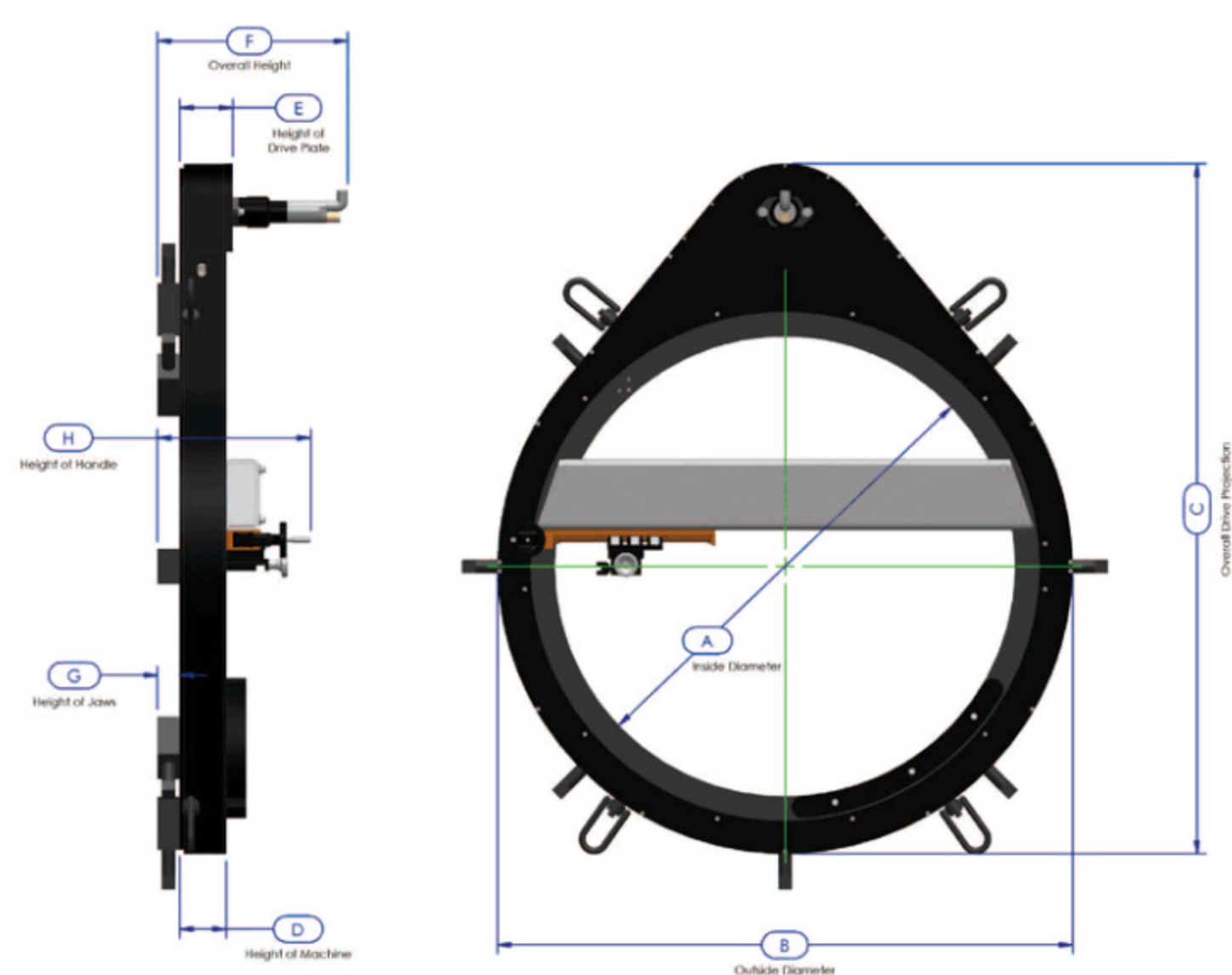

Description	21 inch	30 inch	32 inch	40 inch	42 inch	52 inch	62 inch	72 inch
"A" Inside Diameter	21.125 in	30 in	32.125 in	40 in	42.125 in	52.125 in	62.125 in	72.125 in
"B" Outside Diameter	-	43.375 in	45.125 in	54.625 in	54.625 in	66.75 in	66.75 in	85.375 in
"C" Drive Projection	-	57 in	67.25 in	67.25 in	67.25 in	79.5 in	79.5 in	97 in
"D" Machine Height	4.375 in	5.25 in	5.25 in	5.25 in	5.25 in	5.25 in	5.25 in	5.25 in
"E" Height of Drive Plate	5 in	5.75 in	5.75 in	5.75 in	5.75 in	6.25 in	6.25 in	6.25 in
"F" Motor Height	20 in	20 in	20.75 in	20.75 in	20.75 in	21.25 in	21.25 in	21.25 in
"G" Jaw Height	3.5 in	3.5 in	3.5 in	3.5 in	3.5 in	3.5 in	3.5 in	3.5 in
"H" Handle Height	13.5 in	13.5 in	13.5 in	13.5 in	13.5 in	13.5 in	13.5 in	13.5 in
Base Thickness	1.625 in	2 in	2 in	2 in	2 in	2 in	2 in	2 in
Bridge Size	4in x 4in	4in x 6in	4in x 6in	4in x 6in	4in x 6in	4in x 6in	4in x 6in	4in x 8in
# of Jaws	4	4	4	4	4	8	8	8
Machine Weight	725 lb	1050 lb	1125 lb	1400 lb	1475 lb	1525 lb	1725 lb	1950 lb

Recommended Air Supply for proper performance = 3/4 inch diameter line with 70 cfm at 90 psi

Specifications

Power:
Pneumatic